

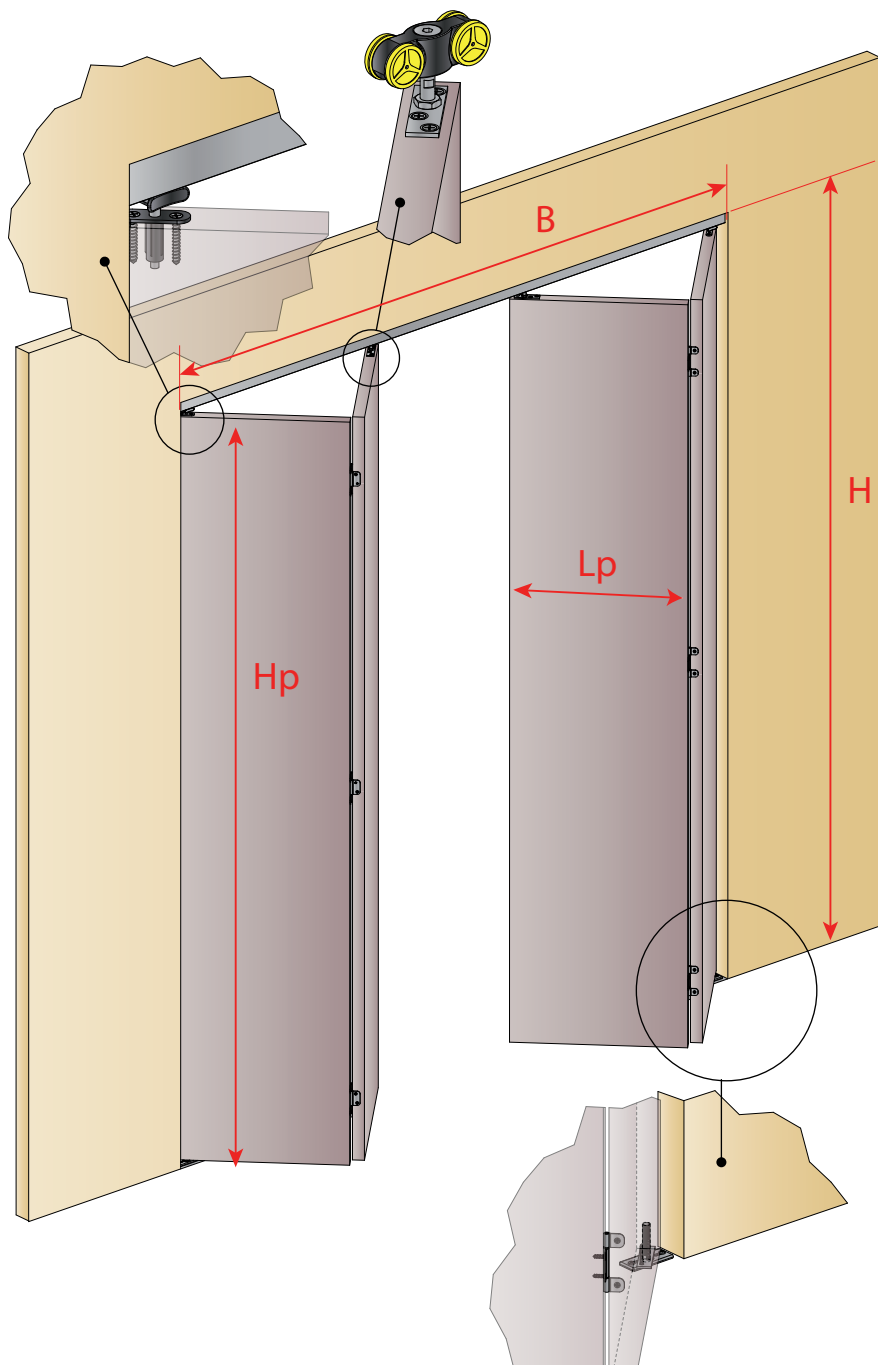

PANNEAU - TÜR < 40 KG
PANNEL - PUERTA < 40 KG



**A utiliser exclusivement pour les placards et portes d'intérieur
To be used only for interior doors and wardrobes
Nur für Wandschränke und Innentüren
Uso exclusivo para armario y puertas de paso**

H = Hauteur de baie
Opening height
Öffnungshöhe
Altura del hueco

B = Largeur de baie
Opening width
Öffnungsbreite
Anchura del hueco

** Montage représenté avec 2+2 panneaux.
Assembly shown with 2+2 panels.
Montage für 2+2 Flügel.
Montaje presentado con 2+2 hojas*

| RÉF. SET NB ART.-NR. | RAIL TRACK SCHIENE PERFIL | NB PANNEAUX QTY PANELS FLÜGELANZAHL N° HOJAS | B (MM) | H (MM) |
|----------------------------|------------------------------------|---|-----------|-----------|
| TANGO40-120 | ✓ | 2 | 1200 | 2500 max. |
| TANGO40-150 | ✓ | 2 | 1500 | |
| TANGO40-180 | ✓ | 2 + 2 | 1800 | |
| TANGO42 | ✗ | 2 | 1500 max. | |

Nota: Toutes les cotes de ce document sont indiquées en mm
Note: All dimensions in this document are given in mm
Hinweis: Alle Maße dieses Dokuments sind in mm angegeben
Nota: Todas las cotas del documento están indicadas en mm

**ENCOMBREMENT & DIMENSIONS DES PANNEAUX / PANEL SIZE AND DIMENSIONS /
PLATZBEDARF & FLÜGELMASSE / TALLA Y MEDIDAS DE LAS HOJAS**

2 + 2

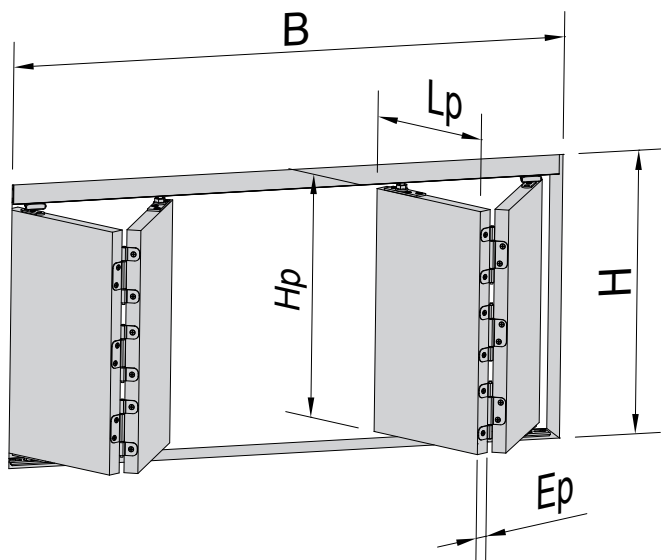

Hp Max. : 2500
Lp Max. : 750
Ep: 16 à 40

40 Kg max.

2

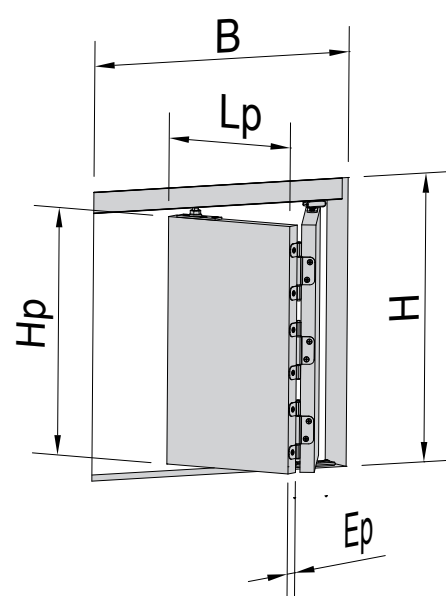

A

Déterminer les dimensions de baie par rapport aux dimensions des panneaux
Determine the size of opening compared to the dimensions of the panels
Bestimmen Sie die Öffnungsmasse im Vergleich zu den Flügelmassen.
Determinar las dimensiones del hueco en función de las medidas de las hojas

Z* =

| Ep | Z |
|--------------|----|
| 16 > Ep > 22 | 4 |
| 22 > Ep > 28 | 6 |
| 28 > Ep > 32 | 8 |
| 32 > Ep > 40 | 12 |

| | | |
|-------------------|-----------------------|-----------------------|
| 1504C3 | 2 + 2 | 2 |
| | $B = 4Lp + 3.6 + Z^*$ | $B = 2Lp + 1.2 + Z^*$ |
| | $H = Hp + 64$ | |

| | | |
|-------------------|-----------------------|-----------------|
| 1504PI | 2 + 2 | 2 |
| | $B = 4Lp + 1.2 + Z^*$ | $B = 2Lp + Z^*$ |
| | $H = Hp + 64$ | |

B

Déterminer les dimensions des panneaux par rapport aux dimensions de baie
Determine the dimensions of the panels relative to the size of opening
Bestimmen Sie die Flügelmassen im Vergleich zu den Öffnungsmassen
Determinar las dimensiones de las hojas en función de las dimensiones del hueco

Z* =

| Ep | Z |
|--------------|----|
| 16 > Ep > 22 | 4 |
| 22 > Ep > 28 | 6 |
| 28 > Ep > 32 | 8 |
| 32 > Ep > 40 | 12 |

| | | |
|-------------------|--------------------------------|--------------------------------|
| 1504C3 | 2 + 2 | 2 |
| | $Lp = \frac{B - 3.6 - Z^*}{4}$ | $Lp = \frac{B - 1.2 - Z^*}{2}$ |
| | $Hp = H - 64$ | |

| | | |
|-------------------|--------------------------------|--------------------------|
| 1504PI | 2 + 2 | 2 |
| | $Lp = \frac{B - 1.2 - Z^*}{4}$ | $Lp = \frac{B - Z^*}{2}$ |
| | $Hp = H - 64$ | |

**1- PRÉPARATION ET MONTAGE PANNEAUX / PREPARATION AND MOUNTING PANELS /
VORBEREITUNG UND FLÜGELMONTAGE / PREPARACIÓN Y MONTAJE HOJAS**

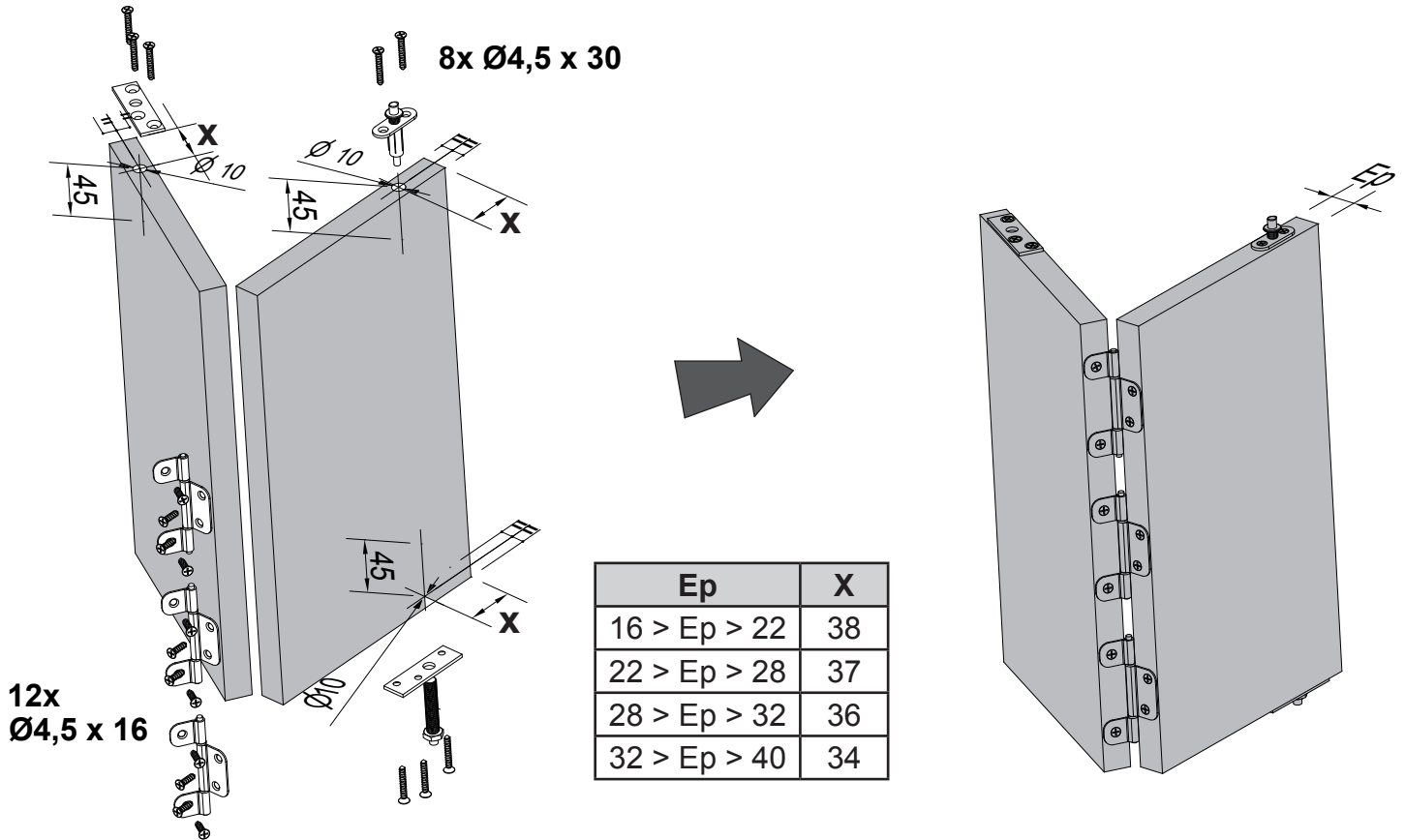

**2- EQUIPEMENT DU RAIL ET MONTAGE PIVOT BAS / RACK ASSEMBLY AND LOWER
PIVOT/ ZUSAMMENBAU DER SCHIENE UND MONTAGE DES BODENLAGERS /
EQUIPAMIENTO DEL PERFIL Y MONTAJE PIVOTE BAJO**

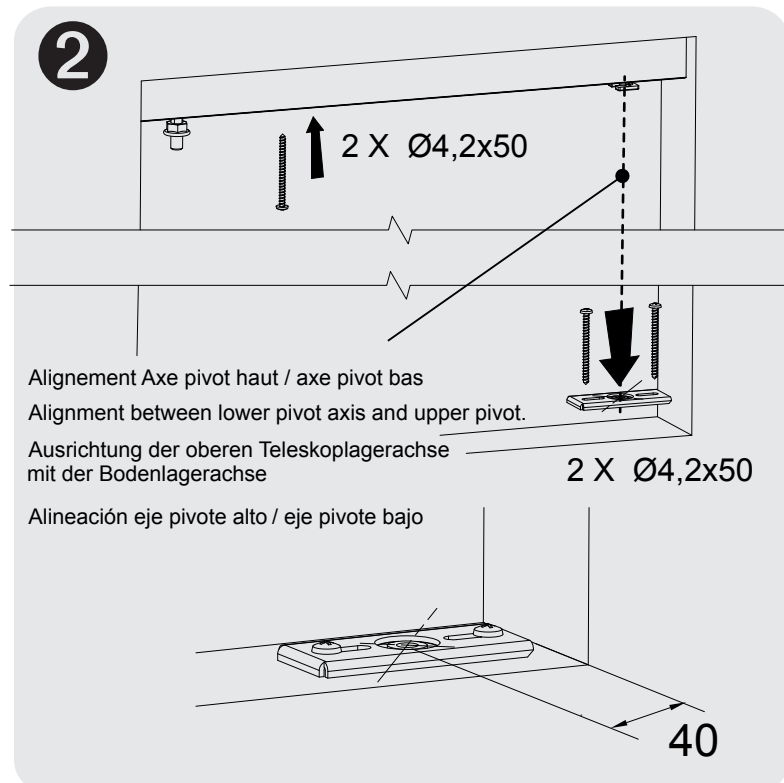
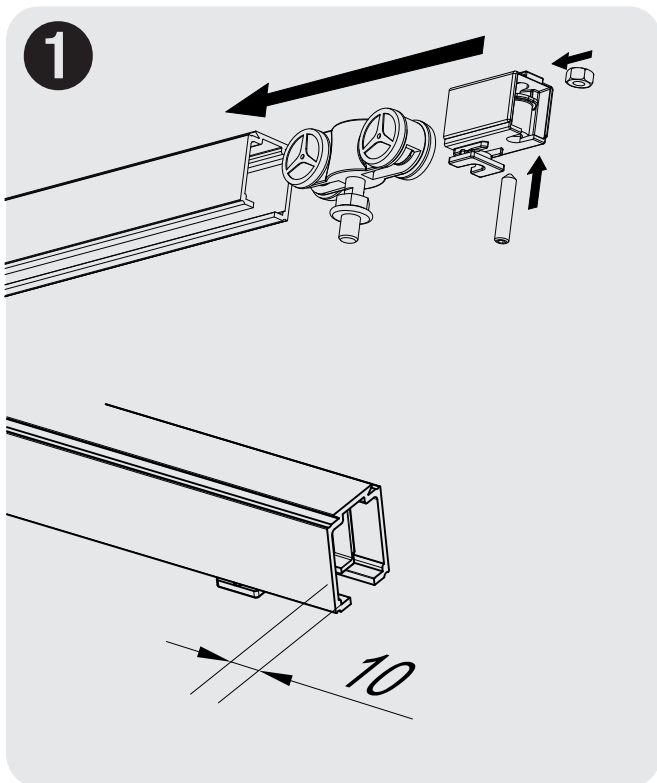

3- MONTAGE DES PANNEAUX SUR LE RAIL / MOUNTING PANELS ON THE TRACK / FLÜGELMONTAGE AUF DER SCHIENE / MONTAJE HOJAS SOBRE EL PERFIL

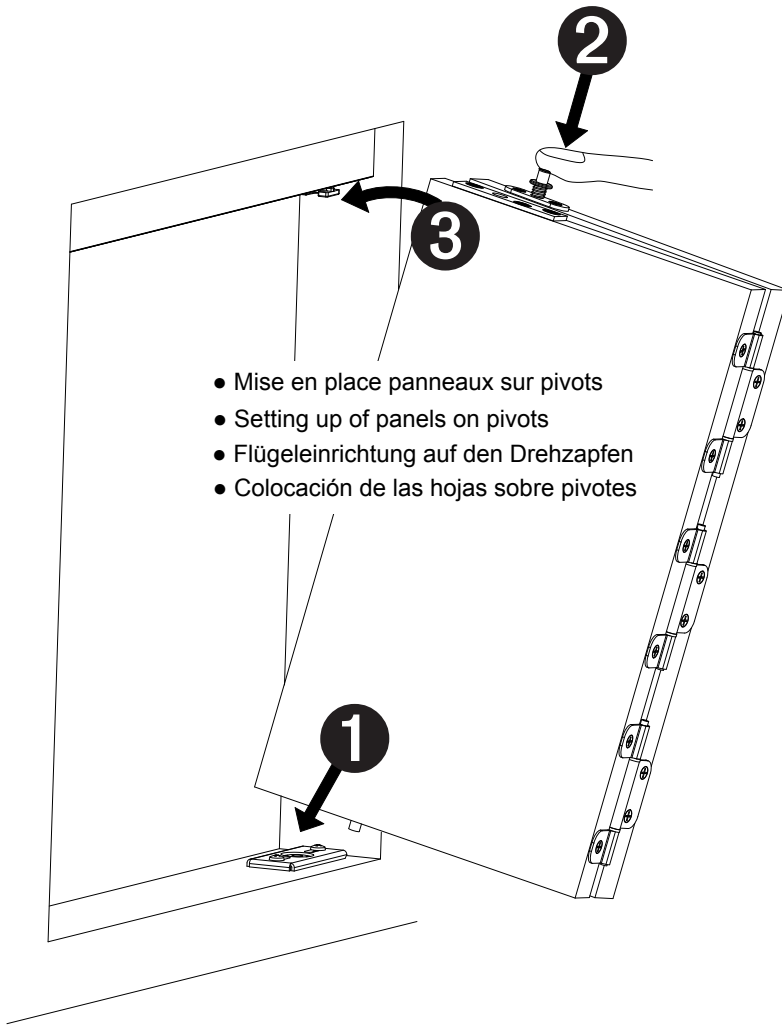

- Mise en place panneaux sur pivots
- Setting up of panels on pivots
- Flügeleinrichtung auf den Drehzapfen
- Colocación de las hojas sobre pivotes

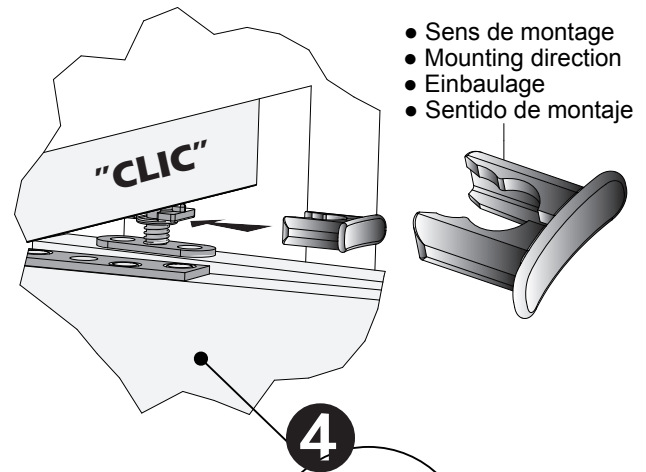

- Sens de montage
- Mounting direction
- Einbaulage
- Sentido de montaje

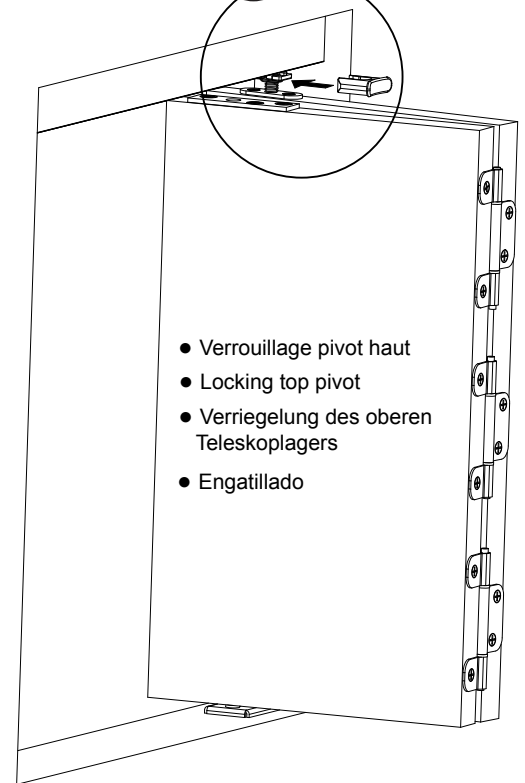

- Verrouillage pivot haut
- Locking top pivot
- Verriegelung des oberen Teleskoplagers
- Engatillado

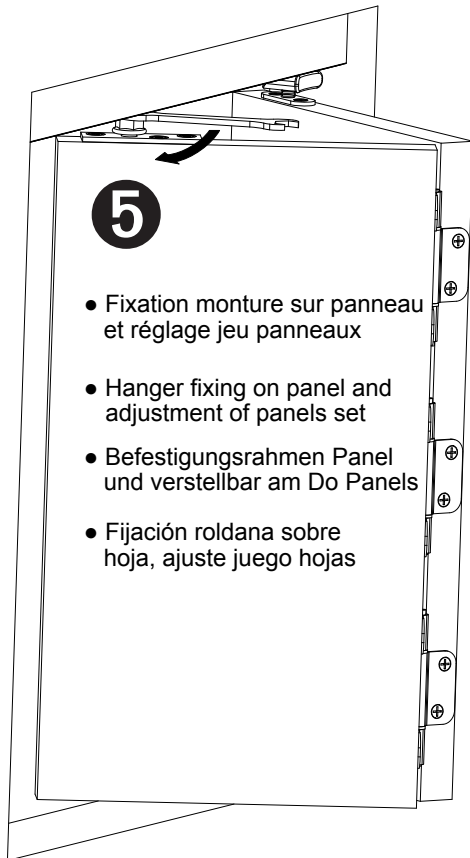

- 5**
- Fixation monture sur panneau et réglage jeu panneaux
 - Hanger fixing on panel and adjustment of panels set
 - Befestigungsrahmen Panel und verstellbar am Do Panels
 - Fijación roldana sobre hoja, ajuste juego hojas

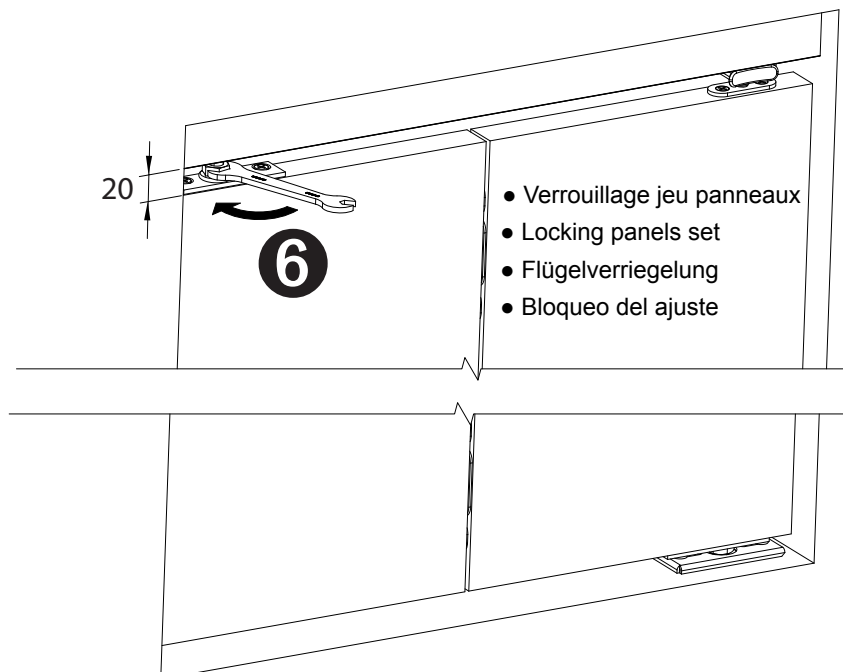

- 6**
- Verrouillage jeu panneaux
 - Locking panels set
 - Flügelverriegelung
 - Bloqueo del ajuste